

FILTRATION EQUIPMENT

Compact Reverse Flushers Code 5075

Conflow is renowned the world over as the leading supplier of specialist components and systems for dust suppression, fire suppression and all aspects of water control in underground coal Mining.

Today Conflow products can be found operating both on the surface and underground in all the major mining industries, from coal to gold, in more than 30 countries around the world. Furthermore, wherever minerals are moved in bulk – such as quarries, power stations and steel works - Conflow products are helping to reduce the negative impact on the local environment.

At Conflow our aim is to provide you with a comprehensive range of services to meet your individual needs.



Description

The **Conflow Code 5075** - Compact Reverse Flushers provides filtration in fluid systems with the minimum amount of downtime for element cleaning.

The unit includes a shut off valve prior to the filter element. Not only can this be used to isolate the system being fed, but the handle used for this purpose also controls the back flushing operation.

The control handle features a ratchet, which ensures the back flushing sequence takes place every time the valve is turned from ON to OFF.

The ratchet mechanism also enables the unit to be installed where space is limited. The element used is the 'V' wire type, which is especially effective for back flushing use.

Typical Applications

- -Filtration of water to: - Longwall faces -shearers -continuous miners -belt sections - emulsion tanks

FILTRATION EQUIPMENT

Compact Reverse Flushers Code 5075

Features

- 2" BSP & NPT versions available
- Maximum working pressure 70 bar
- Low pressure drop
- Primary and secondary flush cycles
- Unique, ratchet handle operation
- 3/4" drain port

Specifications

Dimension	2"
A	395
B	197
C	335
D	135
E	101.5
F	150
G	14 \emptyset
WEIGHT	26 Kg

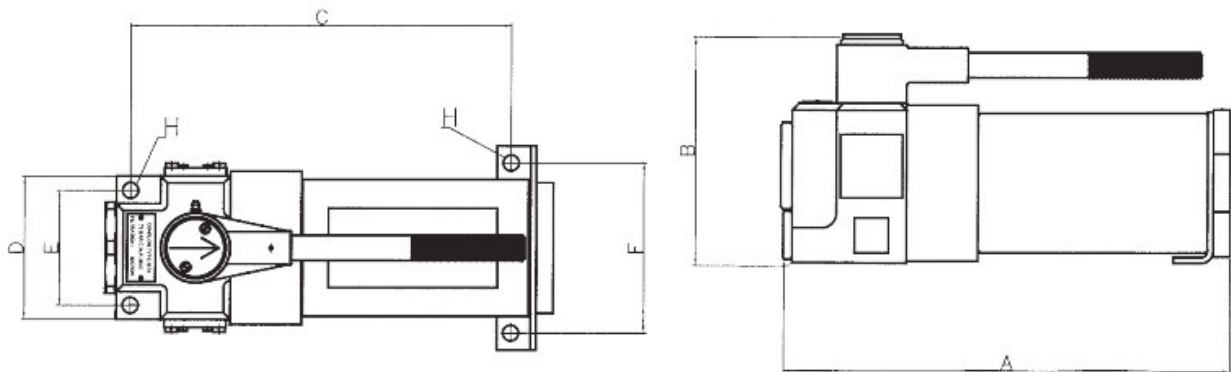
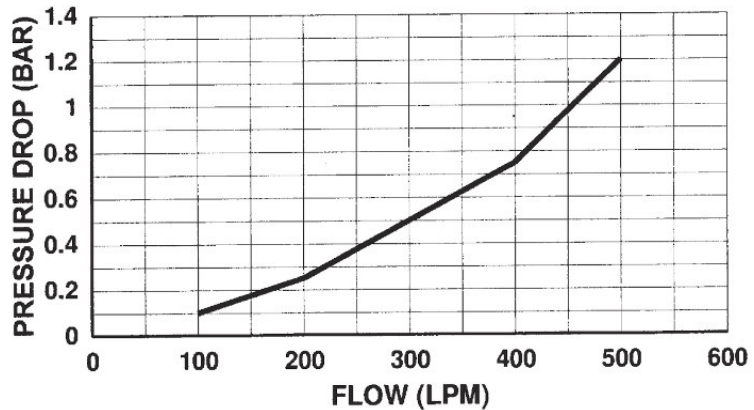

The information on this data sheet is accurate to the best of Conflow's knowledge, however we reserve the right to alter the product specification at any time. For any specific updated detail, please contact us.